



Centrifugal Fan

Operators Manual

1. INTRODUCTION

When you purchased your Kice heavy duty industrial fan, you bought an air mover that has proven to be the best design based on thousands of installations and years of proven reliability and operation.

We are proud of our products and the people at Kice Industries who build them. At Kice, we start in our own foundry and follow the construction standards and manufacturing techniques that have proven superior over the last 60 years.

The results of our development work and input from users have resulted in the present design of the Kice industrial fans.

This owner's manual is intended as a guide for proper installation, operation and maintenance to keep your Kice fan operating safely and efficiently on the job. Service and spare parts information are also included for your benefit.

Sincerely,

Drew Kice
President
Kice Industries, Inc.

WARRANTY

The Company warrants the equipment manufactured by the Company to be free of defects in material and workmanship for a period of one (1) year from the date of shipment. Kice agrees to repair or replace, at its option, any parts found to be defective in the opinion of the Company. Kice is not liable for any costs in connection with the removal, shipment or reinstallation of said parts. This warranty does not apply to abrasion, corrosion, erosion, abuse or misuse of the product. Assistance by Kice in system layout or selecting equipment does not imply Kice's responsibility.

Buyer agrees to look to the warranty, if any, of the manufacturer or supplier of equipment manufactured by others and supplied by Kice for any alleged defects in such equipment and for any damages or injuries caused thereby or as a result thereof. Where work is made to measurements or specifications furnished by the Buyer, Kice does not assume any responsibility for the accuracy of Buyer's specifications. Kice will not assume responsibility for alteration or repairs unless the same are made with the written consent and approval of Kice.

PURCHASER SHALL BE RESPONSIBLE FOR COMPLIANCE WITH ELECTRICAL MANUFACTURER'S RECCOMENDATIONS, UNDERWRITERS CODE AND ALL SAFETY PRECAUTIONS

Kice extends no other warranty for any of its products other than the above express warranty and there are no other warranties, express or implied, including warranties of merchantability, fitness for a particular purpose or otherwise which extend beyond the above limited express warranty. Kice and its dealers shall not in any event be liable for consequential or incidental damages and the terms and conditions stated herein provide Buyer's sole and exclusive remedy. Any actions for breach of this agreement or warranty must be commenced within one year after the cause of action has occurred.

TABLE OF CONTENTS

1. INTRODUCTION	2
2. GENERAL INFORMATION	4
3. SAFETY PRECAUTIONS	6
4. RECEIVING, HANDLING, AND INSTALLATION	8
5. FAN MAINTENANCE	12
6. TROUBLESHOOTING - COMMON FAN PROBLEMS	16
7. ILLUSTRATED PARTS LIST	17

IMPORTANT:

Write down the **MODEL** and **SERIAL NUMBER** of the Kice Industrial Fan.

For additional information, application assistance or special service, you should contact the factory. We will need to know the **MODEL** and **SERIAL NUMBER** of your Kice Industrial Fan. For ready reference, please record this information and the date of delivery or installation on the lines below. See the General Information section for the location of the model and serial number.

Model: _____

Serial Number: _____

Date of Delivery or Installation _____ / _____ / _____

2. GENERAL INFORMATION

The purpose of this manual is to assist owners and operators in maintaining and operating the Kice Industrial Fan. Please read it carefully; information and instructions furnished can help you achieve years of dependable performance. Separate manuals are included for auxiliary equipment that makes up an air system, such as airlock valves, cyclones and fans. They contain additional information that may not be repeated in this manual. You are urged to read all manuals before attempting any operation or repair of the equipment in the system. If these manuals are not included in your owner's packet, contact our customer service department.

USING THIS MANUAL

General operation, adjustment and maintenance guidelines are outlined for owners and operators of the Kice Industrial Fan. Operating conditions vary considerably and cannot be addressed individually. Through experience, however, operators should have no difficulty in developing good operating, safety and monitoring skills.

The term "**disconnect and lockout**" as used in this manual means that power to the equipment has been completely disconnected through the use of "**Lockout and Tagout Procedures**".

Directions used in this manual, for example **RIGHT** or **LEFT. CLOCKWISE** or **COUNTERCLOCKWISE**, refer to directions when facing the drive side of the fan.

Photographs and illustrations were current at the time of printing, but subsequent production changes may cause your Kice Industrial Fan to vary slightly in detail. Kice Industries, Inc., reserves the right to redesign and change the equipment as deemed necessary, without notification. If a change has been made to your Kice Industrial Fan that is not reflected in this owner's manual or the Illustrated Parts List, write or call Kice Industries, Inc., for current information and parts.

MODEL AND SERIAL NUMBER

The model of the Kice Industrial Fan, serial number and date of manufacture can be found stamped on the metal identification plate located on the housing on the opposite side of the inlet.

KICE INDUSTRIAL FAN PARTS AND SERVICE

Use original Kice Industrial Fan replacement parts only. These parts are available from Kice Industries, Inc. To obtain prompt, efficient service, always provide the following information when ordering parts:

1. Correct part description and number, as given in the Illustrated Parts List section of this manual.
2. Correct model number.
3. Correct serial number.

For assistance in service or ordering parts, contact the customer service department:

**Kice Industries, Inc.
5500 Mill Heights Drive
Wichita, KS 67219-2358
Phone 316-744-7151; Fax 316-744-7355**

GENERAL INFORMATION CONTINUED

IMPORTANT: Any unauthorized modification, alteration, or use of non-approved attachments or drive units voids the warranty and releases Kice Industries, Inc., from any liability arising from subsequent use of this equipment. Each type of Industrial Fan is designed to be used in a specific type of system. Using the Kice Industrial Fan for a purpose other than that for which it was designed could result in personal injury, as well as, product or property damage.

Kice equipment is designed and built to provide years of operation. As with any equipment, the following rules are essential for trouble-free operation:

- Proper installation
- Regular maintenance
- Correct operation within original design parameters
- Proper application within a process

Failure to properly install, maintain or operate Kice equipment can result in a variety of problems, including but not limited to: poor equipment performance, decreased equipment life, equipment failure, or dangerous operating conditions.

The Kice Industries product line includes a variety of equipment, all of which can be custom-made to suit your application. Your Kice equipment was chosen based on your specification of process, product and your application requirements for capacity, operating conditions, operating parameters, etc. It is essential that your Kice equipment be installed, maintained and operated under the conditions for which it was originally designed and specified. Should your process needs change, please consult with Kice Industries prior to utilizing the equipment under different conditions.

MOTOR AND DRIVE PARTS AND SERVICE

The motor and drive components are covered by the manufacturer's warranty. If there is a problem, check with the local supplier or service representative.

3. SAFETY PRECAUTIONS



Figure 1

This safety alert symbol is used on equipment, safety decals and in manuals to call your attention to an important safety message warning you of possible danger to your personal safety. When you see this symbol (Figure 1), be alert; your personal safety or the safety of other persons is involved. Follow the instructions in the safety message.

HAZARD LEVELS



DANGER (RED) – Danger is used to indicate the presence of a hazard that **WILL** cause **SEVERE** personal injury, death, or substantial property damage if the warning is ignored.



WARNING (ORANGE) – Warning is used to indicate the presence of a hazard that **CAN** cause **SEVERE** personal injury, death, or substantial property damage if the warning is ignored.



CAUTION (YELLOW) – Caution is used to indicate the presence of a hazard that **WILL** or **CAN** cause **MINOR** personal injury or property damage if the warning is ignored.



NOTICE (BLUE) – Notice is used to indicate installation, operation, or maintenance information that is important, but not hazard-related. Hazard warnings should never be included under the Notice signal word.



WARNING: All owners and operators should read this manual, or be instructed in safe operating and maintenance procedures, before attempting to uncrate, install, operate, adjust, or service this equipment.

SAFETY DECALS

The safety decals on the fan should not be removed, covered over, painted, or otherwise become illegible. If this occurs, the decals should be replaced immediately. Contact our customer service department for replacements.

SAFETY PRECAUTIONS CONTINUED

- Do not attempt to install, connect power to, operate or service your new fan without proper instruction and until you have been thoroughly trained in its use by your employer.
- Do not attempt to work on, clean or service the fan, or open or remove any protective cover, guard, grate or maintenance panel until the POWER has been turned off and LOCKED OUT, and the fan rotor has come to a complete stop.
- Do not manually override or electrically bypass any protective device.
- Do not connect power to or operate the fan unless all moving parts are covered and all covers, guards, grates and maintenance panels are in place and securely fastened.
- Do not abuse, overload, mistreat or misuse the fan or attempt to operate the fan if it is in need of service, lubrication, maintenance or repair.
- Never place any part of your body near rotating members or moving parts of the fan.
- If the fan is not equipped with factory supplied drive and guard, then all rotating members and moving parts must be completely enclosed before connecting power and before operation.
- If the fan is equipped with a maintenance panel or access door incorporating a Protective Interlocking Limit Switch (PLS), the PLS must be interlocked with all electrical controls. This is to prevent all motors or powered devices on the unit from being energized if any protective cover, guard, grate or maintenance panel is open or removed. Never attempt to manually override or electrically bypass a safety device. The interlock function of the PLS must be tested and logged daily by supervisory personnel.
- Many fans are installed and wired to start automatically or be controlled from remote locations. Keep clear of all moving parts on industrial equipment at all times.
- The fan must be equipped with a properly functioning Protective Interlocking Electrical Control Switch (PCS), a Padlockable Manual Power Lockout Switch, and with the other basic safety equipment listed above. On-Off, interlock and padlock functions of the PCS must be tested and logged daily by supervisory personnel.
- It is the owner's and the employer's responsibility to adequately train the employee-operator in the proper and safe use of the equipment. Written safety programs and formal instruction are essential. All new employees must be made aware of company policies and operating rules, especially the established safety and health procedures. Refresher training of experienced employees in the potential hazards of the job is important. Up-to-date training records must be maintained at the job site.
- Special attention must be devoted to outside contractors engaged to enter and perform work on equipment or in the workplace. Special care must be exercised to insure all such personnel are fully informed of the potential hazards and follow plant rules – with special emphasis on explosion proof electrical tools and cutting or welding in unsafe environments.
- Keep the workplace cleaned up and free of dirt and dust at all times. Do not attempt to work on slippery or unsafe ladders or work platforms when maintenance or repair work is being performed on the fan.
- Do not climb on ladders or work on platforms unless maximum load rating is posted. Do not exceed maximum load ratings when installing or servicing the fan.
- Never allow any kind of metal or other foreign objects to enter a fan while in operation.
- All fan inlet and discharge openings must be completely enclosed to prevent human access while the equipment is operating, and must remain enclosed until POWER IS TURNED OFF AND LOCKED OUT. Keep away from the moving parts of the fan during operation.
- Operate safely at all times. Use personal protective equipment when and where appropriate, such as hard hats, helmets, gloves, earplugs, and eye protection devices. Keep personal protective equipment in good repair and convenient to the operator.
- Drive components must be inspected and adjusted after transportation and periodically as required by operating conditions. Check sheaves and coupling alignment and spacing, V-belt tension, set screws, keys, fasteners, bearings, shafts and motor, as appropriate to job conditions.
- High voltage and rotating parts can cause serious or fatal injury. Only qualified, trained, and experienced personnel should perform installation, operation and maintenance of electrical machinery. Make sure that the motor and the frame of the fan is effectively grounded in accordance with OSHA safety and health standards, the National Electrical Code and local codes.
- Never stand under any kind of hoist or lifting mechanism, whether or not it is loaded or in operation. Never stand under or near a fan or component when it is being lifted.
- Qualified personnel, before each use, must carefully inspect all lifting devices. Never use a lifting device to transport equipment. Never use a lifting device that is damaged, deteriorated, or in any way in need of repair.
- All protective covers, guards, grates, maintenance panels, switches and warning decals must be kept in place and in good repair. Any equipment with a damaged, malfunctioning, defective, or missing protective device must be taken out of service until the protective device can be repaired or replaced.
- Any device powered by air or hydraulic pressure must be equipped with a properly functioning Padlockable Manual Pressure Lockout and Internal Pressure Relief Valve (PRV).
- Any equipment that is used in the processing of explosive materials in hazardous environments requires an evaluation on the part of the user and operator of proper and adequate monitoring equipment, dust control, explosion relief venting, and electrical equipment enclosures. Do not use your equipment in hazardous environments unless it has been properly equipped for the hazard.
- It is ultimately the operator's responsibility to implement the above listed precautions and insure proper equipment use, maintenance and lubrication. Keep these instructions and list of warnings with your machine at all times.

WORK SAFELY AT ALL TIMES!!!

4. RECEIVING, HANDLING, AND INSTALLATION

RECEIVING AND INSPECTING

Kice Industries, Inc., has prepared your new fan for shipment in accordance with the Uniform Freight Classification. It has been thoroughly inspected at the factory and, barring damage in transit, should be in excellent condition upon arrival.

The fan and accessories should be inspected upon receipt for any shipping damage. Turn the fan wheel by hand to see that it rotates freely and does not bind. If dampers or shutters are provided, check these accessories for free operation of all moving parts.

When a carrier signs the Kice Industries, Inc., bill of lading, the **carrier accepts the responsibility** for any subsequent shortages or damage, evident or concealed, and **the purchaser must make any claim against the carrier**. Evident shortage or **damage should be noted on the carrier's delivery document** before signature of acceptance. Inspection by the carrier of damage, evident or concealed, must be requested. After inspection, issue a purchase order for necessary parts or arrange for return of the equipment to Kice Industries, Inc., for repair.

HANDLING AND STORAGE

Kice fans are shipped completely assembled and skidded when size permits. These units may be handled and moved using good rigging techniques, being careful to avoid concentrated stresses that will distort any of the parts. Items or parts of the fan that are shipped knocked down will be clearly labeled for reassembly.

If the fan is not to be installed promptly, store it in a clean, dry location to prevent rust and corrosion of steel components. If outdoor storage is necessary, protection should be provided. Cover the inlet and outlet to prevent the accumulation of dirt and moisture inside the housing. Cover the motor with waterproof material. Refer to the Fan Maintenance section of this manual regarding bearings (page 17) for further storage instructions.

Check dampers for free operation and lubricate moving parts prior to storage. Inspect the stored unit periodically. Rotate the wheel by hand every two weeks to redistribute the grease on internal bearing parts.

FAN INSTALLATION

Kice fan wheels are dynamically balanced when fabricated. Each wheel has been test run on the balancer to check for conformance to Kice vibration standards. Kice fan wheels are unique in that the wheel utilizes a Browning hub with a split taper bushing to insure concentric placement on the shaft and to insure that the wheel will retain its balance. (See the Fan Maintenance section for installation instructions.)

To insure proper operation, the unit must be adequately supported and properly installed. All ductwork or stacks should be independently supported as excess weight may distort the fan housing and cause contact between moving parts. Where vibration isolators are used, consult Kice Industries, Inc., for proper location and adjustment.

SLAB MOUNTED UNITS

A correctly designed and level concrete foundation provides the best means of installing floor-mounted fans. The mass of the base must maintain the fan/driver alignment, absorb normal vibration, and resist lateral loads. The overall dimensions of the concrete base should extend at least six inches beyond the outline of the fan base. The weight of the slab should be two to three times the weight of the rotating assembly, including the motor. The foundation requires firmly anchored fasteners, such as the anchor bolts shown in Figure 1. Hammer drilled expansion fasteners can be used in less demanding applications.

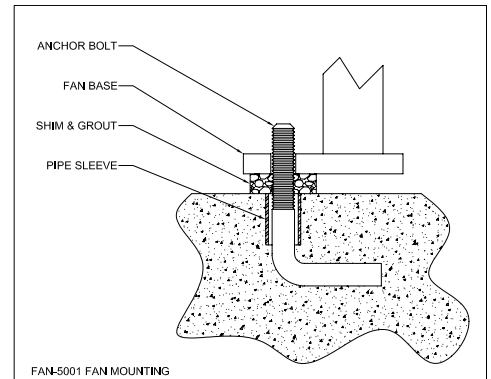

Figure 2

Move the fan to the mounting location and lower it over the anchor bolts, leveling the fan with shims around the bolts. Fasten the fan securely. If grouting is used, shim the fan at least $\frac{3}{4}$ inch from the concrete base (Figure 2).

STRUCTURAL STEEL MOUNTED UNITS

When an elevated or suspended structural steel platform is used, it must have sufficient bracing to support the unit load and prevent side sway. The platform should be of welded construction to maintain permanent alignment of all members.

V-BELT DRIVE

On arrangement #9, 9F and 9FB fans, the V-belt drive is normally factory installed. In some cases, the drive is removed to facilitate the installation of the fan or the customer provides the drive. The following procedure should be used to mount the V-belt drive.

Installation

1. Remove all foreign material from the fan and motor shafts. Coat both shafts with machine oil for easier mounting. Mount the belt guard back plate at this time if it is not already in place.
2. Mount the sheaves onto the shafts, checking the sheave bores and bushings for nicks or burrs. Avoid using force. If resistance is encountered, lightly polish the shaft with crocus cloth until the sheave slides on freely. Tighten tapered bushing bolts sequentially so that equal torque is applied to each.
3. Adjust the motor on its base to a position closest to the fan shaft. Install the belts by working each one over the sheave grooves until all are in position. Never pry the belts into place. On Kice arrangement #9, 9F or 9FB fans, sufficient motor adjustment is provided for easy installation of the proper size belts.
4. Adjust the sheaves and the motor shaft angle so that the sheave faces are in the same plane. Check this by placing a straightedge across the face of the sheaves. Any gap between the straightedge and sheave faces indicates misalignment. Important: This method is only valid when the width of the surface between the belt edge and the sheave face is the same for both sheaves. When they are not equal, or when using adjustable pitch sheaves, adjust so that all belts are approximately equal tension. Both shafts should be at right angles to the center belt.

RECEIVING, HANDLING, AND INSTALLATION CONTINUED

Belt Tensioning

1. Check belt tension with a tensioning gauge and adjust the tension using the motor rail adjustment screws. Excess tension shortens bearing life while insufficient tension shortens belt life, can have adverse effects on fan performance, and may cause vibration. The lowest allowable tension is that which prevents slippage under full load. Belts may slip during start-up, but slippage should stop as soon as the fan reaches full speed. For more precise tensioning methods, consult the drive manufacturer's literature.
2. Recheck setscrews, rotate the drive by hand and check for rubbing, and reattach the belt guard.
3. Belts tend to stretch somewhat after installation. Recheck tension after several days of operation. Check sheave alignment, as well as, setscrew and/or bushing bolt tightness.

COUPLING

On arrangement #8 fans, the motor is direct coupled to the fan shaft. Coupling alignment should be checked after installation and prior to start-up. Alignment is set at the factory, but shipping, handling and installation can cause misalignment. Also, check for proper coupling lubrication. For details on lubrication and for alignment tolerances on the particular coupling supplied, see the manufacturer's installation and maintenance supplement in the shipping envelope.

Installation

1. Most Kice arrangement #8 fans are shipped with the direct drive coupling factory installed. In some cases, however, either the motor is removed to facilitate the installation of the fan or the customer provides the motor. The following procedure should be used to install the coupling.
2. Remove all foreign material from the fan and motor shafts and coat both shafts with machine oil for easier mounting of the coupling halves.
3. Mount the coupling halves onto each shaft, setting the gap between the faces as specified by the coupling manufacturer. Avoid using force. If mounting difficulty is encountered, lightly polish the shaft with crocus cloth until the halves slide on freely.

Alignment

1. Align coupling to within manufacturer's limits for parallel and angular misalignment (see Figure 3). A dial indicator can also be used for alignment where greater precision is desired. Adjustments should be made by moving the motor to change the shaft angle, and by the use of foot shims to change the motor shaft height. Do not move the fan shaft or bearing.
2. When correctly aligned, install the flexible element and tighten all the fasteners associated with the coupling and the motor base.
3. Recheck the alignment and the gap after a short period of operation, and recheck the tightness of all the fasteners in the coupling assembly.

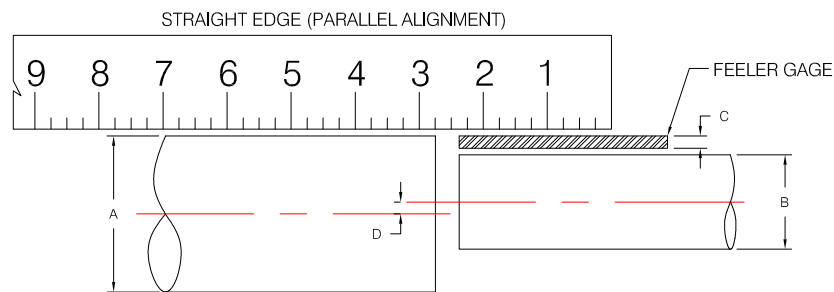

$$\frac{A - B}{2} = C \text{ (FEELER GAGE THICKNESS)}$$

$$D = \text{MISALIGNMENT}$$

Figure 3

RECEIVING, HANDLING, AND INSTALLATION CONTINUED

START-UP

Safe operation and maintenance includes the selection and use of appropriate safety accessories for the specific installation. This is the responsibility of the system designer and requires consideration of the equipment location and accessibility, as well as, adjacent components. All safety accessories must be installed properly prior to start-up.

Safe operating speed is a function of air temperature and wheel design. Do not, under any circumstances, exceed the maximum safe fan speed published in the Kice Fan Performance bulletin, which is available from Kice Industries, Inc.

Procedure

1. If Kice did not supply the drive components, verify with the manufacturer that the starting torque is adequate for the speed and inertia of the fan.
2. Inspect the installation prior to starting the fan. Check for any loose items or debris that could be drawn into the fan or dislodged by the fan discharge. Check the interior of the fan as well. Turn the wheel by hand to check for binding.
3. Check drive installation and belt tension.
4. Check the tightness of all setscrews, nuts and bolts. When furnished, tighten hub setscrews or bolts to the proper torque.
5. Install all remaining safety devices and guards. Verify that the supply voltage is correct and wire the motor. "BUMP" the starter to check for proper wheel rotation.
6. Use extreme caution when testing the fan with the ductwork disconnected. Apply power and check for unusual sounds or excessive vibration. If either exists, see the Troubleshooting section of this manual. To avoid motor overload, do not run the fan for more than a few seconds if the ductwork is not fully installed. On larger fans, the normal operating speed may not be attained without motor overload, unless the ductwork is attached. Check for correct fan speed and complete the installation. Ductwork and guards must be fully installed for safety.

If a problem is detected, SHUT THE FAN DOWN IMMEDIATELY. Lock out the electrical supply. Check carefully for the cause of the trouble and correct as necessary.

After a brief period of operation (even if the fan appears to be operating satisfactorily), shut down the fan, lock out the electrical supply and recheck the following items:

1. Check and tighten all hold-down (securing) fasteners on the feet of the fan base.
2. Spin the fan wheel by hand to see if rotation is free and does not bind or rub.
3. Inspect the fan wheel to see if it is rotating the proper way for the fan housing.
4. Check all setscrews tighten as necessary.
5. Check V-belt drive or coupling for alignment – check belt tension and adjust if necessary.
6. Check V-belt drive for proper sheave selection and placement (make sure the sheaves are not reversed).
7. Properly secure all safety guards.
8. Secure all access doors to the fan housing and the ductwork.

The fan may now be put into operation. However, during the first eight hours of operation, it should be periodically observed and checked for excessive vibration and noise. At this time, checks should also be performed on the motor input current and the motor and fan bearing temperatures to insure that they do not exceed the manufacturer's recommendations.

After eight hours of satisfactory operation, the fan should be shut down and the power locked out in order to check the following items and adjust if necessary:

1. Check and tighten all hold-down (securing) fasteners on the feet of the fan base.
2. Check all setscrews and tighten as necessary.
3. Check V-belt drive or coupling for alignment – check belt tension and adjust if necessary.
4. Properly secure all safety guards.

After twenty-four hours of satisfactory operation, the fan should be shut down and the power locked out in order to check belt tension and adjust if necessary.

5. FAN MAINTENANCE

Kice fans are manufactured to high standards with quality materials and components. Proper maintenance will ensure a long and trouble free service life.



Do not attempt any maintenance on a fan unless the electrical supply has been completely disconnected and locked out. In many cases, a fan wheel can windmill despite the removal of all electrical power. The rotating assembly should be blocked securely before attempting maintenance of any kind.

The key to good fan maintenance is regular and systematic inspection of all fan parts. Inspection frequency is determined by the severity of the application and local conditions. Strict adherence to an inspection schedule is essential. Regular fan maintenance should include the following:

1. Check the fan wheel for any wear or corrosion, as this can cause catastrophic failures. Check also for the buildup of material that can cause the wheel to be unbalanced, resulting in vibration, bearing wear and serious safety hazards. Clean or replace the wheel as required.

NOTE: Shut the fan down immediately if there is any sudden increase in fan vibration.

2. Check the V-belt drive for proper alignment and tension (see V-belt Drive under Section 4 of this manual). If the belts are worn, replace them as a set, matched to within manufacturer's tolerances. Lubricate the coupling of direct-driven units and check for alignment (see Coupling under Section 4 of this manual).
3. Lubricate the fan bearings, but do not over lubricate (see Lubrication under this section for detailed specifications).
4. Felt shaft seals require no maintenance, although worn seals should be replaced. When lip-type shaft seals are provided, lubricate them with "NEVER-SEEZ" or another anti-seize compound.
5. During any routine maintenance, all setscrews and bolts should be checked for tightness (see Figures 6 for correct torque).
6. When installing a new wheel or inlet section, the proper wheel to inlet clearance must be maintained (see Figures 4 and 5 for correct dimensions for full width wheels).

FAN MAINTENANCE CONTINUED

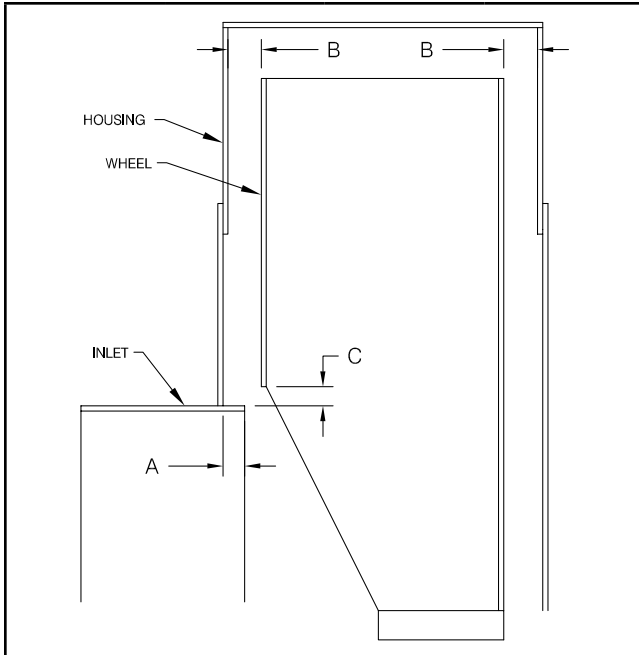

Figure 4

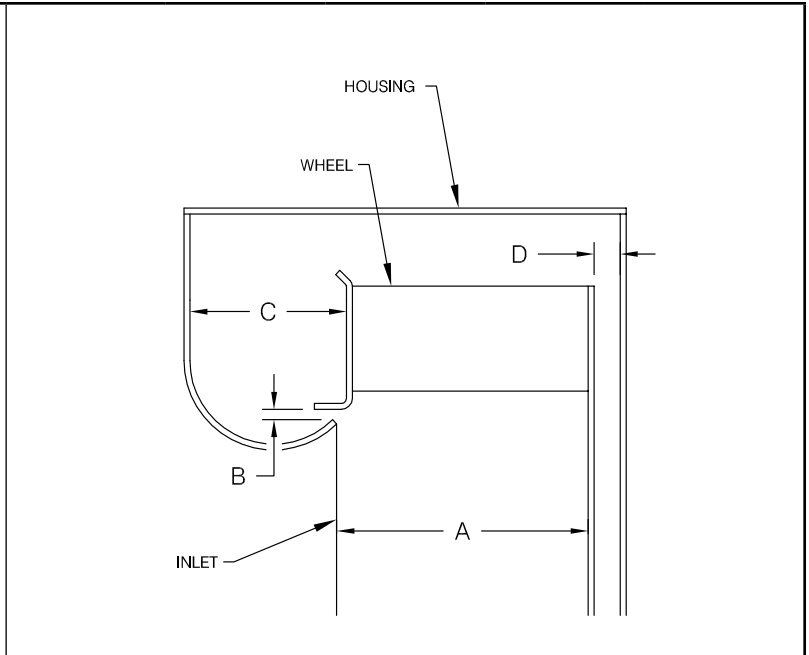

Figure 5

Fan Size	A	B	C	Fan Size	A	B	C	D
FC 5	1/2"	27/32"	3/8"	FA 18	7"	1/8"	4 7/8"	1 5/8"
FC 7	1/2"	21/32"	1/2"	FA 22	8 1/4"	1/8"	6 3/16"	1 3/4"
FC 9	1/2"	13/16"	9/16"	FA 24	9 1/4"	1/8"	7 5/16"	1"
FC 11	1/2"	3/4"	9/16"	FA 27	10 1/8"	1/8"	7 3/8"	2"
FC 13	1/2"	3/4"	9/16"	FA 30	11 1/4"	1/8"	8 5/16"	2 5/8"
FC 15	1/2"	3/4"	5/8"	FA 33	12 1/4"	1/8"	9 3/8"	2 7/8"
FC 17	1/2"	25/32"	11/16"	FA 36	13 3/8"	3/16"	10 5/16"	3 7/16"
FC 19	1/2"	25/32"	5/8"	FA 40	14 3/4"	3/16"	11 1/2"	3 11/16"
FC 21	1/2"	25/32"	5/8"	FA 44	16 1/4"	3/16"	12 13/16"	4 1/16"
FC 23	1/2"	1 3/32"	3/4"	FA 49	17 7/8"	3/16"	14 1/16"	4 1/2"
FC 26	1"	1 5/16"	13/16"	FA 54	19 3/4"	1/4"	15 11/16"	4 9/16"
FC 29	1"	1 13/16"	3/4"	FA 60	21 3/4"	1/4"	17 15/16"	4 1/16"
FC 33	2"	1 13/16"	13/16"	FA 66	24"	1/4"	19 1/2"	5"
FC 37	2"	1 7/8"	1"	FA 73	26 1/2"	1/4"	21 15/16"	4 13/16"
FC 41	2"	2 1/16"	1"					
FC 45	2"	2 1/8"	1"					

FAN MAINTENANCE CONTINUED

WHEEL HUB BOLT TORQUE (IN LBS.)

Grade 5 Steel Bolts

Bushing Size	Bolt Size	Torque
HP1	3 ea. 5/16 x 1	192 in.lbs.
Q1 & Q2	3 ea. 3/8 x 1 1/4	348 in.lbs.
R19 & R26	3 ea. 3/8 x 1 3/4	348 in.lbs.
U33 & U41	3 ea. 5/8 x 2 3/4	1680 in.lbs.

Figure 6

Installation of a Kice fan wheel is different than most other fans because of the hub design. The Kice fan wheel uses a Browning hub with a split taper bushing to insure accurate placement on the shaft. Using a taper hub and bushing insures that the fan wheel will be centered and the balance is the same as when it left the factory.

Check the hub and bushing and remove all foreign material from the fan shaft, the hub and the bushing. Inspect the surfaces and edges to insure that there are no burrs. Clean the machined surfaces of any grit or dirt and coat with a light film of oil. Place the fan wheel onto the shaft inside the housing. Slide the bushing onto the shaft and into the hub. Slide the wheel forward on the bushing and insert the bolts through the bushing flange into the three tapped holes in the hub. Check the wheel clearances inside the housing (see Figures 4 and 5).

Tighten each bolt in turn and then use a torque wrench to set each bolt to the proper torque (see Figure 6). To insure that the bushing and hub are properly seated, tap the fan wheel with a hammer and then retighten the bolts with a torque wrench. In most instances, the bolts will tighten another few degrees. Rotate the wheel and listen for any rubbing sound between the wheel and housing.

BEARINGS

Any stored bearing can be damaged by condensation caused by temperature variations. Therefore, Kice fan bearings are filled with grease at the factory to exclude air and moisture. Such protection is adequate for shipment and subsequent immediate installation.

For long term or outdoor storage, mounted bearings should be regreased and wrapped with plastic for protection. Rotate the fan wheel by hand at least every two weeks to redistribute grease on the internal bearing parts. Each month the bearings should be purged with new grease to remove condensation, since even a filled bearing can accumulate moisture. Use caution in purging, as excessive pressure can damage seals. Rotate the shaft while slowly adding grease.

OPERATION

Verify that bearing setscrew torque is 25in.-lbs. prior to start-up. Since bearings are completely filled with grease at the factory, they may run at an elevated temperature during initial operation. Surface temperatures may reach 180 degrees Fahrenheit and grease may bleed from the bearing seals. This is normal and no attempt should be made to replace lost grease. Bearing surface temperatures will decrease when the internal grease quantity reaches a normal operating level. Lubrication should follow recommended schedule.

NOTE: Split pillow block bearings are fixed to the shaft with tapered sleeves and generally do not have setscrews.

FAN MAINTENANCE CONTINUED

LUBRICATION

Bearings should be lubricated with good quality lithium-based grease conforming to NLGI Grade 2 consistency.

Example is: Mobil - Mobilux EP2

Do not use “high temperature” greases, as many are not formulated for the high speeds associated with fan bearings.

Add grease to the bearing while running the fan or rotating the shaft by hand. Be sure all guards are in place if lubrication is performed while the fan is operating. Add just enough grease to cause a slight purging at the seals. Do not over lubricate.

NOTE: Regular lubrication is critical to bearing life. Please refer to the bearing manual supplied for proper lubrication schedules. Please contact Kice for additional copies if needed.

6. TROUBLESHOOTING - COMMON FAN PROBLEMS

Problem	Probable Cause/Suggested Remedies
<p>Excessive Vibration</p> <p>A common complaint regarding industrial fans is “excessive vibration”. Kice Industries, Inc., is careful to ensure that each fan is precisely balanced prior to shipment; however, there are many other causes for fan vibration, including:</p>	<ol style="list-style-type: none"> 1. Loose mounting bolts, setscrews, bearings or couplings 2. Misalignment or excessive wear of couplings or bearings 3. Misaligned or unbalanced motor 4. Bent shaft due to mishandling or material impact 5. Accumulation of foreign material on the wheel 6. Excessive wear or erosion of the wheel 7. Excessive system pressure or restriction of airflow due to closed dampers 8. Inadequate structural support, mounting procedures or material 9. Externally transmitted vibration
<p>Inadequate Performance</p>	<ol style="list-style-type: none"> 1. Fan wheel rotating in the wrong direction or installed backwards on the shaft 2. Fan wheel running too slow (drive sheaves incorrectly mounted as a slow down drive instead of a speed up drive) 3. Wheel not properly centered relative to the fan inlet 4. Damaged or incorrectly installed cutoff sheet or diverter 5. Poor system design, closed dampers, air leaks, clogged filters or coils 6. Obstructions or sharp elbows near the fan inlet 7. Sharp deflection of air stream at the fan outlet
<p>Excessive Noise</p>	<ol style="list-style-type: none"> 1. Fan operating near “stall” condition due to incorrect system design or installation 2. Vibration originating elsewhere in the system 3. System resonance or pulsation (type of cavitation) 4. Improper location or orientation of fan intake and discharge 5. Nearby sound reflecting off surfaces 6. Inadequate or faulty design of fan structural supports 7. Loose accessories or components 8. Loose V-belt drive or worn sheaves 9. Worn bearings
<p>Premature component failure</p>	<ol style="list-style-type: none"> 1. Prolonged or major vibration 2. Inadequate or improper maintenance 3. Abrasive or corrosive elements in the air stream or surrounding environment 4. Misalignment or physical damage to rotating components or bearings 5. Bearing failure from incorrect or contaminated lubricant or grounding through the bearing while arc welding 6. Excessive fan speed 7. Extreme ambient or air stream temperatures

7. ILLUSTRATED PARTS LIST

It is recommended that only Kice manufactured and/or supplied replacement parts be used. Kice fan parts are built to be fully compatible with the original fan, using specific alloys and tolerances. These parts carry a standard Kice warranty.

When ordering replacement parts, specify the part name, Kice fan serial number, fan model, fan size, type, configuration (viewed from the drive side), and bearing size or shaft size. Most of this information is on the metal nameplate attached to the fan housing or cheek plate.

Example:

Part required: wheel

Kice serial number: 100515

Fan model: FC19W32 Arr. #9FB

Configuration: Motor right of fan shaft, clockwise rotation, vertical up blast

Bearings: Dodge Grip Tight P2B-GTMAH-207

Suggested replacement parts include:

wheel

Components parts:

damper, shaft, 2 ea. bearings and the inlet and outlet isolation sleeves

BILL OF MATERIAL	
ITEM	DESCRIPTION
A	EYE PLATE w/ SUPPORT LEG
B	TAPER LOCK BUSHING
C	WHEEL w/ HARDWARE
D	HOUSING
E	BASE
F	MOTOR w/ HARDWARE
G	BEARING w/ HARDWARE
H	SHAFT
J	SHAFT GUARD w/ HARDWARE
K	DN SHEAVE w/ BUSHING
L	DR SHEAVE w/ BUSHING
M	V-BELT
N	BELT GUARD w/ HARDWARE

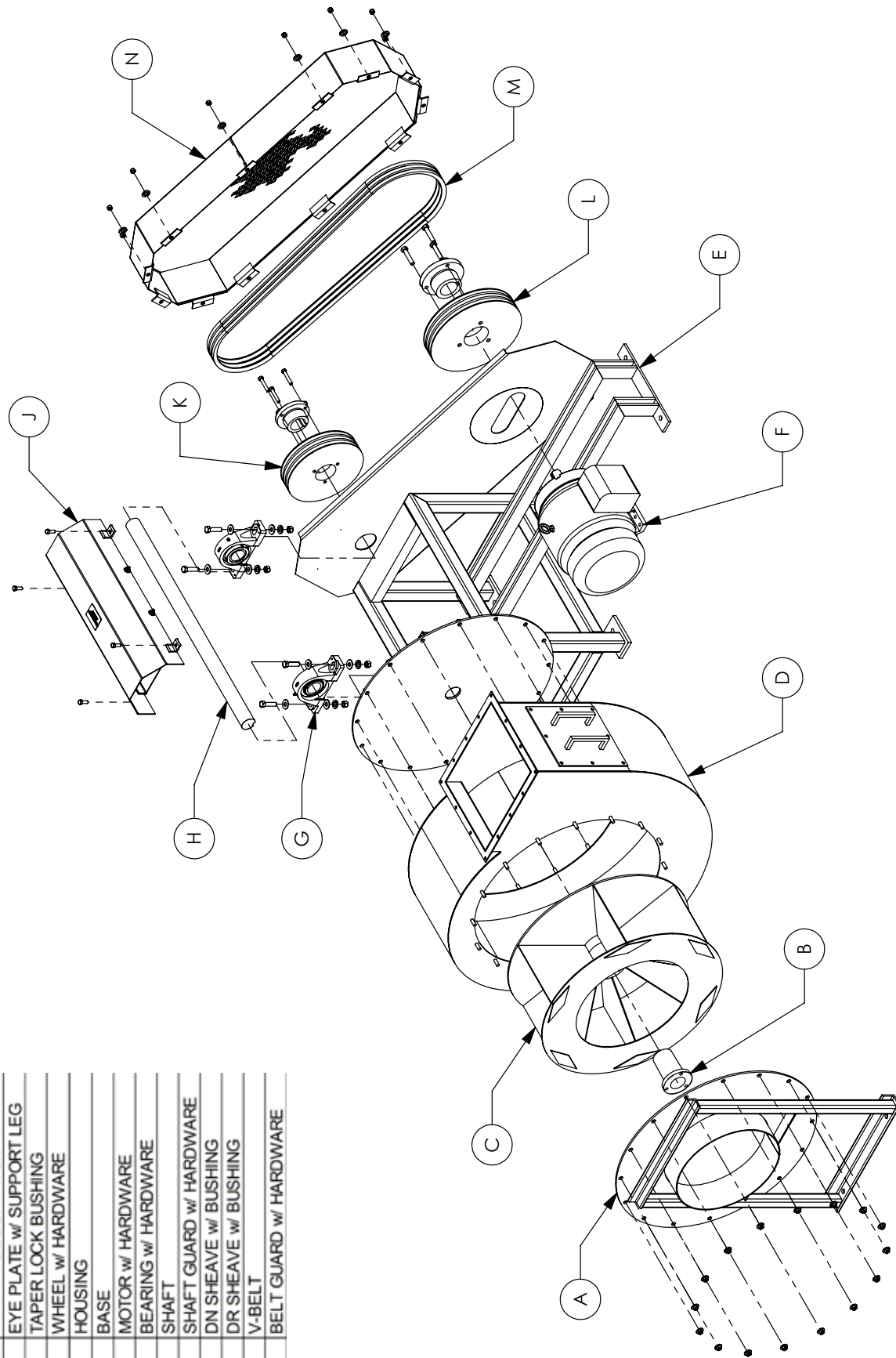

FC SERIES FANS

DESCRIPTION:



KICE INDUSTRIES, INC.

5500 MILL HEIGHTS DR. WICHITA, KANSAS 67219
 PH: (316) 744-7151 FAX: (316) 744- 7355

JBR
 DWN:

02-20-07
 DATE:

FAN-5000
 DWG. NO.

BILL OF MATERIAL	
ITEM	DESCRIPTION
A	EYE PLATE w/ SUPPORT LEG
B	INLET CONE
C	TAPER LOCK BUSHING
D	WHEEL w/ HARDWARE
E	HOUSING
F	BASE
G	MOTOR w/ HARDWARE
H	BEARING w/ HARDWARE
J	SHAFT
K	SHAFT GUARD w/ HARDWARE
L	DN SHEAVE w/ BUSHING
M	DR SHEAVE w/ BUSHING
N	V-BELT
P	BELT GUARD w/ HARDWARE

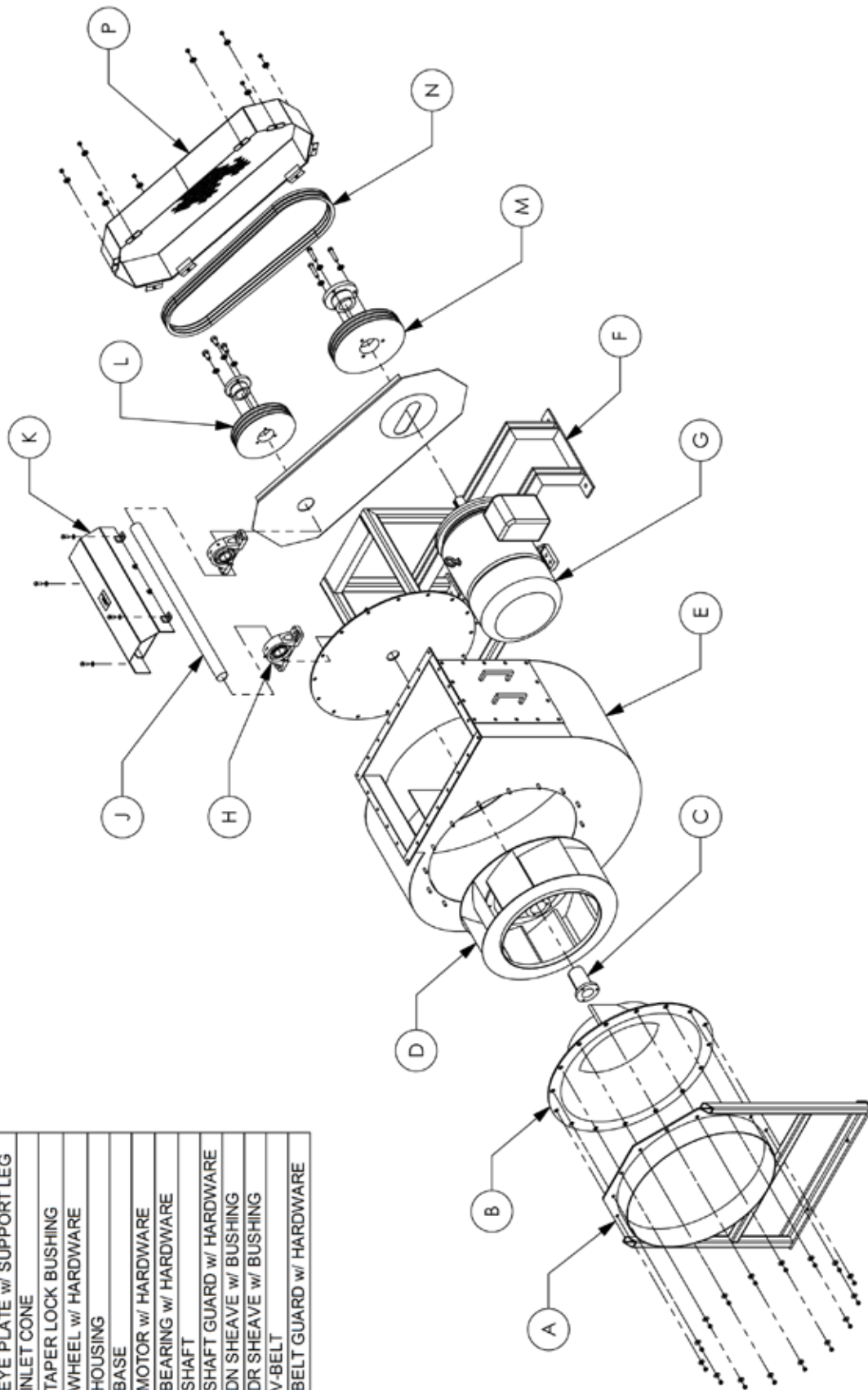

KICE INDUSTRIES, INC.

5500 MILL HEIGHTS DR., WICHITA, KANSAS 67219
 PH: (316) 744-7151 FAX: (316) 744-7355

FA SERIES FANS

DESCRIPTION:

JPG 01-08-10 FAN-5004
 DWN: DATE: DWG. NO.

KICE INDUSTRIES, INC.

5500 N. Mill Heights Dr.

Wichita, KS 67219-2358

(P) 316.744.7151

(F) 316.744.7355

sales@kice.com

kice.com